



AVK GATE VALVE, FLANGED, PN10/16

Series 02/40

EN 558-2 S.3/BS, grey cast iron



AVK gate valves are designed with built-in safety in every detail. The wedge is fully vulcanized with AVK's own drinking water approved EPDM rubber compound. It features an outstanding durability due to the ability of the rubber to regain its original shape, the double bonding vulcanization process and the sturdy wedge design. The triple safety stem sealing system, the high strength stem and the thorough corrosion protection safeguard the unmatched reliability.

Product description:

Flanged gate valve EN 558-2 S.3/BS. For drinking water and neutral liquids to max. 70°C

Design standards:

- EN 1074 part 1 & 2
- Face-to-face dimension according to EN 558 Table 2 Basic Series 3
- Flange drilling to EN1092, PN10/16

Test/Approvals:

- Seat: 1.1 x PN (in bar), Body: 1.5 x PN (in bar). Operation torque test

Features:

- Fixed, integral wedge nut prevents vibration and ensures durability
- Wedge fully vulcanized with drinking water approved EPDM rubber and equipped with wedge shoes to provide smooth operation
- Large conical stem hole in the wedge prevents stagnant water
- Wedge and body guide rails ensure stable operation
- Stainless steel stem with rolled threads for high strength
- Full circle brass thrust collar provides fixation of the stem and low free running torques
- Triple safety stem sealing with an NBR wiper ring, a polyamide bearing with four NBR O-rings, and an EPDM rubber manchette
- Round bonnet gasket fixed in a recess
- Countersunk and sealed bonnet bolts encircled by the bonnet gasket
- Full bore
- Fusion bonded epoxy coating in compliance with DIN 3476 part 1 and EN 14901, GSK approved

Accessories:

Stem cap, handwheel, extension spindle, street cover, flange adaptor and combi-flange



Expect ... **AVR**

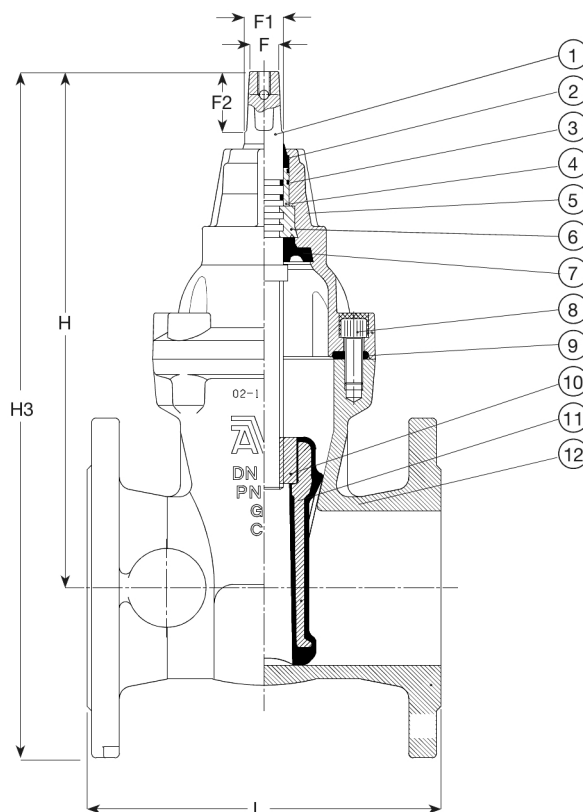

Component list:

1. Stem	Stainless steel 1.4104	7. Manchette	EPDM rubber
2. Wiper ring	NBR rubber	8. Bonnet bolt	Stainless steel A2, sealed with hot melt
3. O-ring	NBR rubber	9. Bonnet gasket	EPDM rubber
4. Bearing	Polyamide	10. Wedge nut	Brass DZR CW626N
5. Bonnet	Ductile iron GJS-500-7 (GGG-50)	11. Wedge	Ductile iron, EPDM encapsulated
6. Thrust collar	Brass DZR CW602N	12. Body	Cast iron GJL-250 (GG-25)

Components may be substituted with equivalent or higher class materials without prior notification.

Dimensions:

DN mm	Flange drilling	L mm	H mm	H3 mm	F mm	F1 mm	F2 mm	Theoretical weight/kg
50	PN10/16	178	241	324	14	17	29	13
65	PN10/16	190	271	364	17	20	34	17
80	PN10/16	203	297	397	17	20	34	20
100	PN10/16	229	334	444	19	22	38	26
150	PN10/16	267	448	591	19	22	38	51
200	PN10	292	562	732	24	28	42	83
200	PN16	292	562	732	24	28	42	83
250	PN16	330	664	864	27	31	42	132
300	PN10	356	740	968	27	31	47	187
300	PN16	356	740	968	27	31	47	187
400	PN10	406	940	1228	32	37	55	287
400	PN16	406	940	1228	32	37	55	287