

Twin-Sphere Rubber Joint with
Floating Flanges

TWINFLEX

Excellent performance for
vibration absorption,
displacement absorption and
high-pressure resistance.



Feature

Achievements

Having been used in more than 20 countries for over 30 years, TOZEN brand products proudly demonstrate their popularity.

Reliability

Unparalleled durability is guaranteed by the distinctive and strict design standards of TOZEN.

Quality

Manufactured in TOZEN's own factory under thorough control with ISO9001 quality management system.



Repetitive pressure fluctuation test

Structure

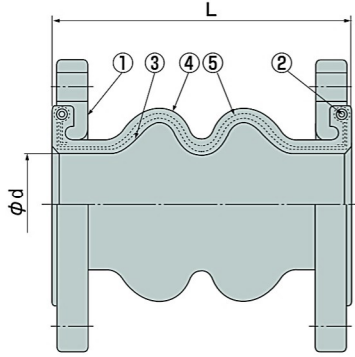

No. Parts	Material
① Flange	Mild Steel / Ductile Iron / S.S.
② Reinforcing Ring	Carbon Steel
③ Inner Rubber	Synthetic Rubber
④ Outer Rubber	Synthetic Rubber
⑤ Reinforcing Cord	Synthetic Fiber

- JIS 10K, ANSI150 and PN16 flange drilling are available for all sizes. For other flange standard, please consult us.
- Ductile iron flanges are available up to 300mm.
- Mild steel and stainless steel flanges are available for all sizes.

Operating Conditions and Performance

Working Temperature vs. Working Pressure

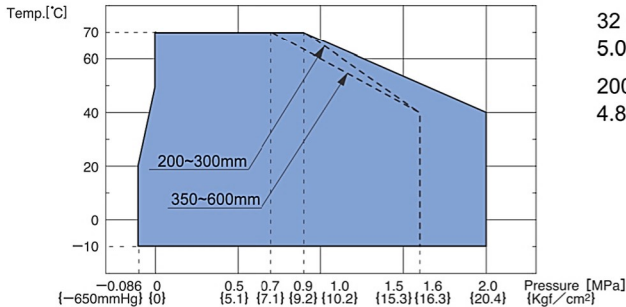

Bursting Pressure:

- 32 ~ 150mm:
5.0MPa or above at normal temp.
- 200 ~ 600mm:
4.8MPa or above at normal temp.

Applications

- This product is mainly applicable for piping systems in commercial and industrial building and plants.
- Applicable fluids are exclusively water including drinking water, cold water, warm water, cooled water and sea water, etc....
- This product can not be used for oil, or boiled water.

Dimensions and Allowable Movements

Nominal Dia.		Diameter (mm)		Mass (Kg)	Allowable Movement (mm)				Installation Tolerances (mm)			
mm	inch	L	φd		T.M.	A.E.	A.C.	A.M.	T.M.	A.E.	A.C.	A.M.
32	1 1/4	175	35	2.2	20	10	20	20°	8	3	6	7.5°
40	1 1/2	175	35	2.3	20	10	20	20°	8	3	6	7.5°
50	2	175	45	3.0	20	10	20	20°	8	3	6	7.5°
65	2 1/2	175	60	3.9	20	10	20	20°	8	3	6	7.5°
80	3	175	70	4.1	20	10	20	20°	8	3	6	7.5°
100	4	225	95	5.3	25	15	30	20°	10	3	6	7.5°
125	5	225	120	7.6	25	15	30	20°	10	3	6	7.5°
150	6	225	145	11	25	15	30	20°	10	3	6	7.5°
200	8	325	195	17	30	20	40	20°	12	3	6	7.5°
250	10	325	245	24	30	20	40	20°	12	3	6	7.5°
300	12	325	290	28	30	20	40	20°	12	3	6	7.5°
350	14	250	340	35	15	15	20	15°	6	3	6	7.5°
400	16	250	390	48	15	15	20	15°	6	3	6	7.5°
450	18	275	440	72	15	15	20	15°	6	3	6	7.5°
500	20	275	490	81	15	15	20	15°	6	3	6	7.5°
600	24	300	591	113	15	15	20	15°	6	3	6	7.5°

·A.C.: Axial Compression, A.E.: Axial Elongation,
A.M.: Angular Movement, T.M.: Transverse Movement

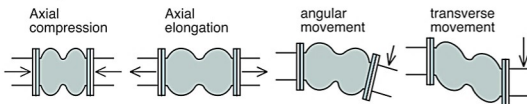

- Mass indicates only the case with JIS 10K (Ductile Iron) flanges. However, mass for 350&400mm is with JIS 10K (Mild Steel) flange.
- Tolerances for installation are included in the allowable movements (Allowable movements = Tolerances for installation + Operating movements).

·Please note that the information in the above table is for single movement only. In case of complex movements, please do adjustment by using the following formula.

$$C.A.E. (C.A.C.) = A.A.E. (A.A.C.) \times \left\{ 1 - \left(\frac{T.M.}{A.T.M.} + \frac{A.M.}{A.A.M.} \right) \right\}$$
 C.A.E. (C.A.C.): Correct Elongation Movement (Correct Compression Movement)
 A.A.E. (A.A.C.): Allowable Elongation Movement (Allowable Compression Movement)
 A.T.M.: Allowable Transverse Movement
 A.A.M.: Allowable Angular Movement

Example: In case of 100mm joint, if 10mm transverse movement is needed, then the correct elongation should be: $C.A.E = 15 \times \left\{ 1 - \left(\frac{10}{25} + \frac{0}{20} \right) \right\} = 9\text{mm}$
 ·There is reaction force from rubber joints due to the load of the internal pressure, so during the installation, please use the metal fittings to fix the pipe tightly to ensure the joints work efficiently. In case the pipe cannot be fixed tightly, please use the control unit for the joints.

Note: The contents of this catalogue are subject to change without notice.

AGENT

TOZEN Corporation

8-4, Asahi, Yoshikawa
Saitama 342-0008 Japan

F2017 V.1